

Product Brochure

製品カタログ
産品目録



ORGAN NEEDLE CO., LTD.

Sewing machine needles

ミシン針

縫紉針

主要寸法
MAIN DIMENSIONS
主要尺寸

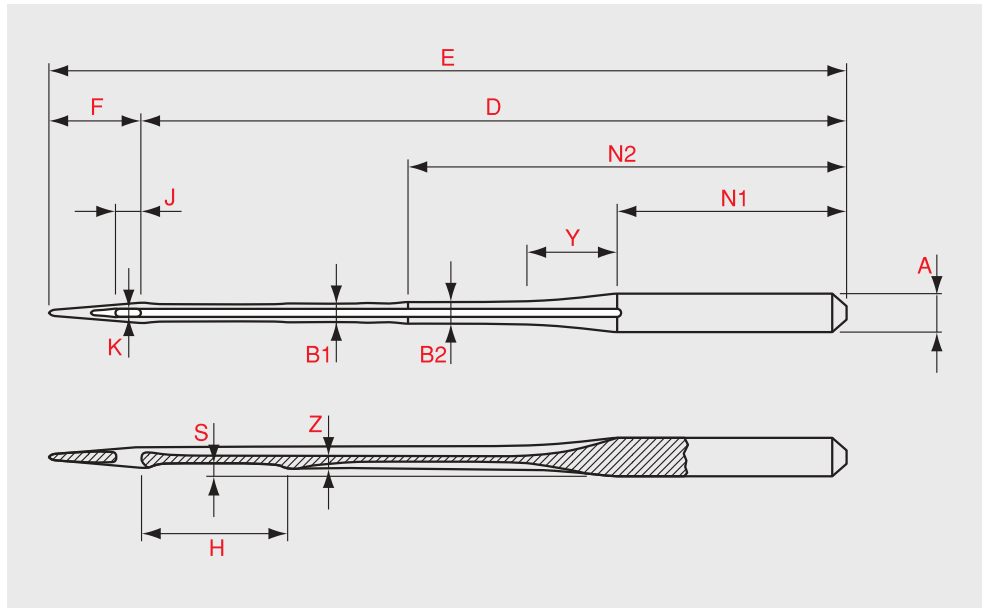

| | | | |
|----------|----------|---------------------------------|--------|
| A | 軸(シャンク)径 | Shank diameter | 針柄直径 |
| B | 幹径 | Blade diameter | 針杆直径 |
| D | 穴上寸法 | Butt to eye length | 針眼上方尺寸 |
| E | 全長 | Total length | 全長 |
| F | 穴先寸法 | Distance from end of eye to tip | 針眼下方尺寸 |
| S | エグリ深さ | Depth of scarf | 針冠深 |
| H | エグリ長さ | Length of scarf | 針冠長 |
| J | 穴縦寸法 | Length of eye | 針眼長 |
| K | 穴横寸法 | Width of eye | 針眼寬 |
| N | 軸寸法 | Length of shank | 針柄尺寸 |
| Z | 溝深さ | Depth of groove | 針槽深 |
| Y | テーパ部寸法 | Length of shank taper | 針肩尺寸 |

ミシン針の主要部位名称
ANATOMY OF THE NEEDLE
縫紉機針的各部名称

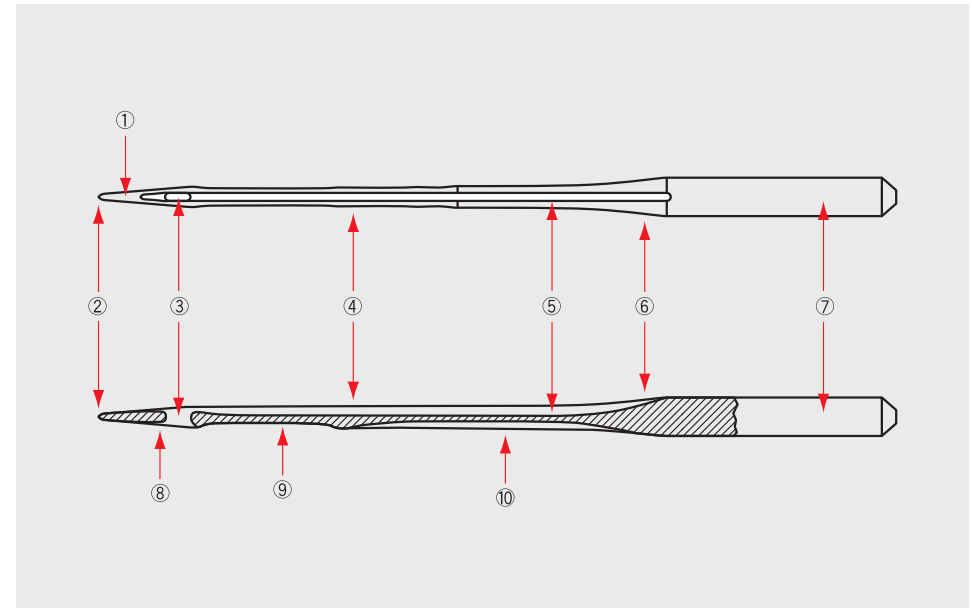

| | | | |
|---|--------|------------------|-----|
| ① | 針先部 | Needle point | 針頭部 |
| ② | 先端 | Tip of the point | 針尖 |
| ③ | 糸穴 | Needle eye | 針眼 |
| ④ | 針幹 | Blade | 針杆 |
| ⑤ | 表溝 | Long groove | 表槽 |
| ⑥ | テーパ部 | Shank taper | 針肩 |
| ⑦ | シャンク・軸 | Shank | 針柄 |
| ⑧ | 短溝 | Point groove | 短槽 |
| ⑨ | エグリ | Scarf | 針冠 |
| ⑩ | 裏溝 | Short groove | 裏槽 |

☆本カタログには、A、D、N、E寸法が記載されています。(E寸法は「二重環縫い関係」のみの記載になります。)

☆The measurements A, D, N and E are given in this brochure. (The measurement for E is shown in the "Double chainstitch" part only.)

☆本目錄登載了各种針的A・D・N・E尺寸。(只有與「雙綫鎖縫紉」有關的產品登載了E尺寸。)

糸と針の関係表

Interrelationship Table (Thread/Needle Sizes)

綫號和針號的關係表

| 呼び番手 | 対応する針番手/Needle Size/針號 | | | |
|------|------------------------|---|---|---|
| | 綿糸 Cotton 全棉縫紉綫 | ポリエステルスパン Polyester spun 滌綸短纖維縫紉綫 | ポリエステルフィラメント Polyester filament 滌綸長絲縫紉綫 | ナイロンフィラメント Nylon filament 尼龍長絲縫紉綫 |
| 120 | 7 | 7 | | |
| 100 | 7~8 | 7~8 | 7 | 7~9 |
| 80 | 7~11 | 7~9 | 7~9 | 7~10 |
| 60 | 8~14 | 8~12 | 7~10 | 7~11 |
| 50 | 10~16 | 10~14 | 8~12 | 9~14 |
| 40 | 14~19 | 12~18 | 11~16 | 11~14 |
| 30 | 16~21 | 14~19 | 14~20 | 16~19 |
| 20 | 19~23 | 19~23 | 18~22 | 18~21 |
| 10 | 20~23 | 20~23 | 19~23 | |
| 8 | 22~24 | 22~24 | 19~24 | |
| 5 | | | 24~25 | |

| | 糸の太さ /Thread Size/ 綫號 | | | | 対応する針番手 Needle Size 針號 |
|-----------------------|-----------------------|------|-----|--------|------------------------------|
| | Tex | dTex | Nm | Ticket | |
| スパン Spun 短纖維縫紉綫 | 16 | 160 | 200 | 200 | 50/6~55/7 |
| | 18 | 180 | 180 | 180 | 55/7~65/9 |
| | 21 | 210 | 140 | 150 | 60/8~80/12 |
| | 27 | 270 | 120 | 120 | 65/9~90/14 |
| | 30 | 300 | 120 | 90 | 70/10~100/16 |
| | 40 | 400 | 75 | 75 | 80/12~110/18 |
| | 60 | 600 | 50 | 50 | 90/14~120/19 |
| | 70 | 700 | 50 | 60 | 90/14~120/19 |
| | 80 | 800 | | 30 | 100/16~125/20 |
| | 105 | 1050 | 30 | 25 | 110/18~130/21 |
| | 120 | 1200 | 25 | 24 | 120/19~160/23 |

※参考資料としてお使い下さい。

※This table is only for reference purposes.

※請作為參考資料。

| | 糸の太さ /Thread Size/ 綫號 | | | | 対応する針番手 Needle Size 針號 |
|-----------------------------|-----------------------|------|-----|--------|------------------------------|
| | Tex | dTex | Nm | Ticket | |
| フィラメント Filament 長絲縫紉綫 | 10 | 100 | | 250 | 55/7 |
| | 12 | 120 | | 230 | 55/7~65/9 |
| | 16 | 160 | 180 | 200 | 55/7~70/10 |
| | 24 | 240 | 160 | 120 | 60/8~80/12 |
| | 30 | 300 | 100 | 80 | 70/10~100/16 |
| | 50 | 500 | | 60 | 80/12~110/18 |
| | 60 | 600 | 40 | 40 | 90/14~125/20 |
| | 80 | 800 | 30 | 30 | 100/16~130/21 |
| | 105 | 1050 | 25 | 25 | 110/18~140/22 |
| | 180 | 1800 | | 20 | 130/21~180/24 |

| | 糸の太さ /Thread Size/ 針號 | | | | 対応する針番手 Needle Size 針號 |
|---------------------------|-----------------------|------|-----|---------------|------------------------------|
| | Tex | dTex | Nm | Ticket | |
| コアスパン Core Spun 包芯綫 | 18 | 180 | 160 | 180 | 60/8~65/9 |
| | 21 | 210 | 150 | 150 | 60/8~70/10 |
| | 24 | 240 | 120 | 120 | 70/10~80/12 |
| | 30 | 300 | 100 | 100 | 70/10~90/14 |
| | 40 | 400 | 75 | 80 | 80/12~100/16 |
| | 50 | 500 | 60 | | 90/14~100/18 |
| | 60 | 600 | 50 | 50 | 90/14~120/19 |
| | 80 | 800 | 36 | 40 | 100/16~120/19 |
| | 105 | 1050 | 30 | 30 | 100/16~140/22 |
| | 140 | 1400 | 25 | 25 | 120/19~160/23 |
| 200 | 2000 | 14 | | 140/22~160/23 | |

| | Denir | 対応する針番手/Needle Size/針號 |
|---------------------------------|-------|------------------------|
| 刺繡糸 Embroidery Thread 綉花綫 | 75 | 60/8~70/10 |
| | 120 | 65/9~75/11 |
| | 200 | 75/11~90/14 |

ミシン針の針先形状及び先端形状
 POINT STYLE and TIP OF THE POINT STYLE
 縫紉機針の針頭形状及針尖形状

| | | | |
|--|------------------------------|---|-------------------------------------|
| 先端形状 Symbol 針頭形状 | | | |
| 針先図 Illustration of Needle Point 針尖圖 | | | |
| オルガン記号 ORGAN Designation 風琴公司記號 | R | TRI | SPI |
| 他社記号 Other Maker Designation 其它公司記號 | R, SET | SD1, TRI TIP | RS, S SET |
| 特徴 Description 特徵 | 正規型 Regular point 標準針頭 | 小三角型 Light triangular point 小三角形頭 | 尖頭細身型 Slim sharp point 尖頭細身形頭 |

表面処理のご紹介

縫製条件に合わせて三種類の表面処理をご用意します。
 *HPのみ#14以下の針では、先端はJボールポイントが標準仕様となっています。

COATING STYLE

We have three types of coatings depending on sewing conditions.
 *Regarding HP coating, the J-ball has been adapted for needles of size #14 and under to maintain consistency.

關於表面處理

針對縫紉條件現在共有三種表面處理方式。
 *HP、#14以下的針的針尖標準為J圓頭。

HP

針熱トラブル
 Trouble due to Needle Heat
 針熱而引起的縫紉問題



LP

粘着トラブル
 Trouble due to Adhesion
 粘着而引起的縫紉問題



PD

摩耗・先つぶれが引き起こすトラブル
 Trouble due to Wear and Point Damage
 磨損・針尖損傷而引起的縫紉問題



Ball Point series

ボールポイント

Ball-Point

圓頭針

工業用ミシン針のすべての種別・番手にボールポイント加工を施すことができます。詳しくはお問い合わせください。

Ball Points can be supplied on all ORGAN needles. Please contact our representative for further information.

圓頭針の加工處理可以對風琴針品牌工業縫紉機針的所有種類的各種型號。具體事宜請向敝公司詢問。

| 先端形状 Symbol 針頭形状 | | | | | | |
|--|-------------------------------|--|---|---------------------------------------|---------------------------------|--|
| 針先図 Illustration of Needle Point 針尖圖 | | | | | | |
| オルガン記号 ORGAN Designation 風琴公司記號 | S | Q | J | B | U | Y |
| 他社記号 Other Maker Designation 其它公司記號 | | RG | SES, FFG, L BALL, SIN, R-K, NYR, BPL | SUK, FG, M BALL, SI R-KB, LAC, BMP | STR, TR, H BALL, KAL, BPH | SKF, G, EH BALL, BIL |
| 特徴 Description 特徴 | スリムポイント Slim point 織細針頭 | Qボール Extra light ball point 極小圓頭 | Jボール Light ball point 小圓頭 | Bボール Medium ball point 中圓頭 | Uボール Heavy ball point 大圓頭 | Yボール Extra heavy ball point 特大圓頭 |

※スリムポイントは、先端がJボールで、糸穴から先端までの針先の形状は当社標準針よりも細身になっています。











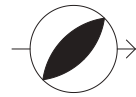

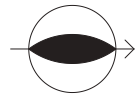
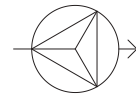



Slim point has adopted a slimmer needle point (from the side of the eye to the tip) along with the J-ball than our regular needle.
細身圓頭針的針尖為J圓頭、從針眼到針尖的針頭部分比標準針細

ボールポイント表示例

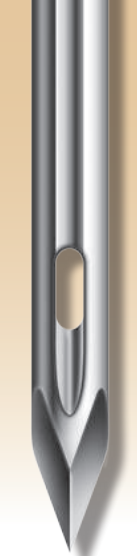
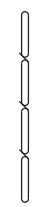
description example of ball point on package
圓頭針的包裝樣例

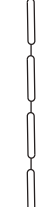
| | | |
|------------------------------|-------------------------------|------------------------------------|
| -10pcs- DPx134 Size 9S | -10pcs- DBx1KN Size 11U | -10pcs- DPx17-NY2 Size 21SPD |
|------------------------------|-------------------------------|------------------------------------|

カッティングポイント
Cutting-Point
刀針

| | | | | | | | |
|---|---|---|--|---|---|---|---|
| <p>先端形状 Symbol 針頭形状</p> |  |  |  |  |  |  |  |
| <p>針先図 Illustration of Needle Point 針尖圖</p> |  |  |  |  |  |  |  |
| <p>縫い目 Stitch 縫跡</p> |  |  |  |  |  |  |  |
| <p>オルガン記号 ORGAN Designation 風琴公司記號</p> | <p>LL</p> | <p>LR</p> | <p>S</p> | <p>P</p> | <p>D</p> | <p>DI</p> | <p>TQ</p> |
| <p>他社記号 Other Maker Designation 其它公司記號</p> | <p>TW, NTW</p> | <p>RTW, NRTW</p> | <p>CR, NCR</p> | <p>W, NW</p> | <p>TRI</p> | <p>DIA</p> | <p>QR, RSQ</p> |

小カッティングポイント
 Small Cutting Point(M)
 小剣尾針

小カッティングポイントタイプをご注文の際は番手の後に「M」を記載してください

When placing an order for the small cutting point, please indicate with an M after the size number

訂購小劍尾針時,請在針號後加上“M”。

| | | | | | | |
|--|------|------|-----|-----|-----|------|
| 先端形状 Symbol 針頭形状 | | | | | | |
| 針先図 Illustration of Needle Point 針尖圖 | | | | | | |
| 縫い目 Stitch 縫跡 | | | | | | |
| オルガン記号 ORGAN Designation 風琴公司記號 | M-LL | M-LR | M-S | M-P | M-D | M-DI |
| 他社記号 Other Maker Designation 其它公司記號 | | | | | SD | |

包装表示例
 PACKAGING
 包裝樣例

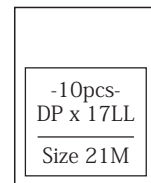

| 針先図 Illustration of Needle Point 針尖圖 | 先端形状 Symbol 針頭形状 | オルガン記号 ORGAN Designation 風琴公司記號 | 他社記号 Other Maker Designation 其它公司記號 | 特徴 Description 特徴 |
|--|------------------------|---------------------------------------|---|---|
| | | EM | R-E0°, LG G ECC SET, SEM, EXEM | 上偏芯 Eccentric towards long groove (down-side of needle) 上偏芯 |
| | | EK | R-E180°, SH G ECC SET, SEK, EXEK | 下偏芯 Eccentric towards short groove (up-side of needle) 下偏芯 |
| | | EL | R-E270°, LF G ECC SET, SEL, EXEL | 左偏芯 Eccentric left 左偏芯 |
| | | ER | R-E90°, RT G ECC SET, SER, EXER | 右偏芯 Eccentric right 右偏芯 |
| | | CL | CL | 短溝左ひねり Left-twist point groove at point 針槽向左扭 |
| | | CR | CR | 短溝右ひねり Right-twist point groove at point 針槽向右扭 |
| | | HR | | ハーフポイント Half round point 半細身針頭 |
| | | HO | | フック Hook point 針鈎 |

| 先端形状 Symbol 針頭形状 | オルガン記号 ORGAN Designation 風琴公司記號 | 他社記号 Other Maker Designation 其它公司記號 | 特徴 Description 特徴 | 先端形状 Symbol 針頭形状 | オルガン記号 ORGAN Designation 風琴公司記號 | 他社記号 Other Maker Designation 其它公司記號 | 特徴 Description 特徴 |
|------------------------|---------------------------------------|---|---|------------------------|---------------------------------------|---|--|
| | DI | DIA | 皮革用 クロスダイヤ For leather Diamond point 皮革用 菱形針頭 | | PS | | 皮革用 織細メス 小 For leather Narrow wedge point 皮革用 狭扁針頭 小 |
| | VR | R TWSP, NRTWSP | 皮革用 45°逆ひねり For leather narrow reversed 45-degree twist point 皮革用 45°反轉 | | SS | | 皮革用 横メス 小 For leather Narrow cross point 皮革用 反狭扁針頭 |
| | PCL | | 皮革用 縦メス 短溝左ひねり For leather Narrow wedge point with left-twist point groove 皮革用 扁針頭 針槽向左扭 | | BUT | | ボタン用 For button 鈕扣用 |
| | PCR | | 皮革用 縦メス 短溝右ひねり For leather Narrow wedge point with right-twist point groove 皮革用 扁針頭 針槽向右扭 | | | | |
| | LLCR | | 皮革用 45°ひねり 短溝右ひねり For leather 45-degree twist with right-twist point groove 皮革用 45°斜扁針頭 針槽向右扭 | | | | |



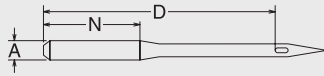















| 記号 SYSTEM SYSTEM SISTEMA 型號 | 他社記号 OTHER MAKER SYSTEM PARALLELSYSTEME SISTEMAS EQUIVALENTES 其他公司型號 | 先端 POINT SPITZE PUNTA 針尖 | ミシン針イラスト ILLUSTRATION OF NEEDLE NADEL FOTO FOTO DE AGUJA 縫紉機針示意图 | 用途 APPLICATION ANMERKUNG NOTAS 用途 | 番手 NEEDLE SIZES NADELSTÄRKEN TAMAÑOS DE AGUJAS 針號 |
|---|--|--------------------------------------|--|---|---|
|---|--|--------------------------------------|--|---|---|



■ 本縫い関係 For Lockstitch 平縫系列

| | | | | | | |
|-----------------|----------------------|--|--|---|---|--|
| DB × 1 | 16 × 231 16 × 257 | | | A:1.62~2.02 D:33.80 N:16.00~10.50 | 1本針本縫い 1-needle lockstitch | 7 8 9 10 11 12 13 14 16 18 19 20 21 22 22½ 23 24 25 55 60 65 70 75 80 85 90 100 110 120 125 130 140 150 160 180 200 |
| DB × 1KN | | | | A:1.62 D:33.80 N:16.00 | 地糸切れ対策針 preventing fabric yarn breakage | 8 9 10 11 12 14 60 65 70 75 80 90 |
| DB × 1KNLE | | | | A:1.62 D:33.80 N:16.00 | 糸締め不良対策 preventing loose seams | 9 10 11 12 65 70 75 80 |
| DB × 1SF | | | | A:1.62 D:33.80 N:16.00 | 地糸切れ対策針 preventing fabric yarn breakage | 8 9 10 11 60 65 70 75 |
| DB × 1NS | | | | A:1.62 D:33.80 N:16.00~10.50 | パッカリング対策 糸引け対策針 preventing seam puckering preventing needle line | 8 9 10 11 12 14 60 65 70 75 80 90 |
| DB × 1 - NY2 | | | | A:1.62~1.90 D:33.80 N:16.00~12.50 | 目飛び対策針 preventing skipped stitches | 9 10 11 12 14 16 18 19 65 70 75 80 90 100 110 120 |
| DB × A20 | 287WK SY6633 | | | A:1.62 D:33.80 N:12.50~10.50 | A寸=1.62mm DB×1 #19~ (shank diameter = 1.62mm) | 19 20 21 22 23 120 125 130 140 160 |
| DB × 287WKH | | | | A:1.63 D:33.90 N:16.00 | DB × 1のF寸短 DB×1 with shorter distance from tip of the point to end of needle eye | 7 8 9 10 11 12 13 14 16 18 19 21 55 60 65 70 75 80 85 90 100 110 120 130 |
| DB × 1KK | 1738KK | | | A:1.62 D:33.80 N:12.50 | 1のN寸短 shorter shank | 11 14 16 75 90 100 |
| DA × 1 | 88 × 1 SY1315 | | | A:1.62 D:29.60 N:14.50 | 1本針本縫い 1-needles lockstitch | 7 8 9 10 11 12 13 14 16 18 19 20 21 22 55 60 65 70 75 80 85 90 100 110 120 125 130 140 |
| DA × 1KN | | | | A:1.62 D:29.60 N:13.50 | 地糸切れ対策針 preventing fabric yarn breakage | 8 9 10 11 60 65 70 75 |
| DI × 3 | | | | A:1.98 D:39.20~39.00 N:14.50 | 靴、袋物縫用 1~2本針本縫い for shoes, bags, etc 1or2-needle lock stitch | 12 14 16 18 19 20 21 22 22½ 23 24 25 26 80 90 100 110 120 125 130 140 150 160 180 200 230 |
| DP × 17 | 135 × 17 | | | A:2.00 D:39.00 N:16.00~13.00 | 1~2本針本縫い厚物用 1or2-needle lock stitch for thick materials | 9 10 11 12 13 14 16 18 19 20 21 22 23 24 25 26 65 70 75 80 85 90 100 110 120 125 130 140 160 180 200 230 |
| DP × 17 - NY2 | | | | A:2.00 D:39.00 N:16.00~13.00 | 目飛び対策針 preventing skipped stitches | 11 12 14 16 18 19 20 21 22 23 75 80 90 100 110 120 125 130 140 160 |
| DP - C80 - NY2 | | | | A:2.00 D:39.00 N:13.00~16.00 | DP × 17 - NY2の平取針 DP×17 - NY2 with flat shank | 18 19 21 22 23 110 120 130 140 160 |
| DP - C119 - NY2 | | | | A:2.00 D:39.00 N:13.00 | DP × 17 - NY2の平取針 DP×17 - NY2 with flat shank | 19 22 23 120 140 160 |
| DP × 17 - SK | | | | A:2.00 D:39.00 N:16.00~13.50 | 目飛び対策針 従来名称:DP×17-SK1 preventing skipped stitches former system:DP×17-SK1 | 14 16 18 19 20 21 22 23 24 90 100 110 120 125 130 140 160 180 |

上記以外にも様々な種類の針があります。詳しくは、お問い合わせください。/ Please Note: we have many other types of needles that are not indicated above. Please contact us for details.

| 記号 SYSTEM SYSTEME SISTEMA 型號 | 他社記号 OTHER MAKER SYSTEM PARALLEL SYSTEME SISTEMAS EQUIVALENTES 其他公司型號 | 先端 POINT SPITZE PUNTA 針尖 | ミシン針イラスト ILLUSTRATION OF NEEDLE NADEL FOTO FOTO DE AGUJA 縫紉機針示意圖 | 用途 APPLICATION ANMERKUNG NOTAS 用途 | 番手 NEEDLE SIZES NADELSTÄRKEN TAMAÑOS DE AGUJAS 針號 |
|--|---|---|---|--|---|
| DP × 17SF | |  |  A:2.00 D:39.00 N:16.00 | 地糸切れ対策針 preventing fabric yarn breakage | 9 10 65 70 |
| DP × 17NS | |  |  A:2.00 D:39.00 N:16.00 | 針穴跡防止 preventing poor needle hole | 14 90 |
| DP × 17LE | |  |  A:2.00 D:39.00 N:16.00 | 糸穴大 large needle eye | 14 16 18 19 20 21 22 23 24 90 100 110 120 125 130 140 160 180 |
| DP × 35R | |  |  A:2.00 D:38.20 N:13.50 | 1~2本針本縫い厚物用 1or2-needle lock stitch for thick materials | 8 9 10 11 12 13 14 16 18 19 20 21 22 22½ 23 23½ 24 25 60 65 70 75 80 85 90 100 110 120 125 130 140 150 160 170 180 200 |
| DP × 35R - NY2 | |  |  A:2.00 D:38.20 N:13.50 | 目飛び対策針 preventing skipped stitches | 14 16 18 19 20 21 22 23 90 100 110 120 125 130 140 160 |
| DP - C126 - NY2 | |  |  A:2.00 D:38.20 N:13.50 | DP × 35R - NY2の平取針 DP × 35R - NY2 with flat shank | 18 19 21 22 110 120 130 140 |
| DP × 35R - SK | |  |  A:2.00 D:38.20 N:13.50 | 目飛び対策針 従来名称：DP×35R-SK1 preventing skipped stitches former system:DP×35R-SK1 | 14 16 18 19 20 21 22 23 90 100 110 120 125 130 140 160 |
| DP - N45 | |  |  A:2.00 D:39.00 N:19.00 | DP × 17の地糸切れ対策針 DP × 17 preventing fabric yarn breakage | 18 110 |
| DP × 17RS | |  |  A:2.00 D:39.00 N:13.00 | 樹脂縫製対策針 | 23 160 |
| | | | | | |
| | | | | | |
| | | | | | |
| | | | | | |

■ 刺繍関係 For Embroidery 刺繍系列

| | | | | | |
|----------------|--|---|--|---|---|
| DB × K5 | |  |  A:1.62~1.90 D:33.80 N:16.00~12.50 | 刺繍用 (DB×1の糸穴大) embroidery (DB × 1 with large needle eye) | 8 9 10 11 12 13 14 16 18 19 60 65 70 75 80 85 90 100 110 120 |
| DB × K5 - NY | |  |  A:1.62 D:33.80 N:16.00 | 強度対策針 DB × K5 with reinforced blade | 8 9 10 11 12 14 60 65 70 75 80 90 |
| DB × K5 - YORI | |  |  A:1.62 D:33.80 N:16.50 | 上糸切れ・ルーピング対策針 preventing upper thread breakage and poor embroidery stitches appearance | 8 9 10 11 60 65 70 75 |
| DB × K5Z1 | |  |  A:1.62 D:33.80 N:16.00 | 刺繍用 for multi-head embroidery machine | 8 9 10 11 12 14 18 21 23 60 65 70 75 80 90 110 130 160 |

上記以外にも様々な種類の針があります。詳しくは、お問い合わせください。/ Please Note: we have many other types of needles that are not indicated above. Please contact us for details.

| 記号 SYSTEM SYSTEME SISTEMA 型號 | 他社記号 OTHER MAKER SYSTEM PARALLELSYSTEME SISTEMAS EQUIVALENTES 其他公司型號 | 先端 POINT SPITZE PUNTA 針尖 | ミシン針イラスト ILLUSTRATION OF NEEDLE NADEL FOTO FOTO DE AGUJA 縫紉機針示意圖 | 用途 APPLICATION ANMERKUNG NOTAS 用途 | 番手 NEEDLE SIZES NADELSTÄRKEN TAMAÑOS DE AGUJAS 針號 |
|--|--|--------------------------------------|--|--|--|
| DB × K5Z1 - NY | | | A:1.62 D:33.80 N:16.50 | 刺繍用強度対策針 DB × K5Z1 with reinforced blade | 9 10 11 12 14 65 70 75 80 90 |
| DB × K5Z2 - NY | | | A:1.62 D:33.80 N:13.50 | 刺繍 厚物、円筒枠用 for cylindrical frame, thick materials | 9 10 11 12 14 65 70 75 80 90 |
| DB × K5Q1 | | | A:1.62 D:33.80 N:16.00 | 刺繍用 for multi-head embroidery machine | 8 9 10 11 12 14 60 65 70 75 80 90 |
| DB × K5KK | | | A:1.62 D:33.80 N:13.50 | N寸短 shorter shank | 9 10 11 12 14 65 70 75 80 90 |
| DB × 5ST | | | A:1.62 D:33.80 N:16.00~11.50 | DB×1の糸穴大 DB×1 with large needle eye | 16 20 22 100 125 140 |
| DB × 7ST | | | A:1.62 D:33.00 N:16.00~11.50 | DB×1の糸穴大 DB×1 with large needle eye | 9 11 12 14 16 18 65 75 80 90 100 110 |
| DB × 9ST | | | A:1.62 D:33.80 N:16.00 | DB×1の糸穴大 DB×1 with large needle eye | 9 11 14 16 18 65 75 90 100 110 |
| PH - C70 | | | A:1.62 N:26.00 | ハンドル刺繍用 for chenille embroidery | 11 14 16 18 19 21 75 90 100 110 120 130 |
| PH - C70LE | | | A:1.62 D:57.65 N:26.00 | ハンドル刺繍用 for chenille embroidery | 14 16 18 90 100 110 |
| PH × 1 | | | A:1.52 N:26.00~10.00 | ハンドル刺繍用 for chenille embroidery | 9 11 12 13 14 15 16 18 19 20 21 22 23 26 65 75 80 85 90 95 100 110 120 125 130 140 160 230 |
| PH × 1SM | | | A:1.46 N:26.00 | ハンドル刺繍用 for chenille embroidery | 14 16 18 19 90 100 110 120 |
| PH × 1TR | | | A:1.46 N:26.00 | ハンドル刺繍用 for chenille embroidery | 12 14 16 18 19 80 90 100 110 120 |
| PH × 1WS | | | A:1.42 N:26.00 | ハンドル刺繍用 for chenille embroidery | 14 16 90 100 |

■ ボタン付け関係 For Button sewing 釘扣系列

| | | | | | |
|--------|---------------------------|--|----------------------------------|------------------------|--|
| TQ × 1 | 29 - S 175 × 1 1985 | | A:1.75 D:37.20 N:11.50 | ボタン付け button sewing | 9 10 11 12 13 14 16 18 19 20 21 22 65 70 75 80 85 90 100 110 120 125 130 140 |
| TQ × 3 | 175 × 3 1661LG | | A:1.75 D:41.50 N:11.50 | ボタン付け button sewing | 11 12 14 16 18 19 20 21 22 75 80 90 100 110 120 125 130 140 |

上記以外にも様々な種類の針があります。詳しくは、お問い合わせください。/ Please Note: we have many other types of needles that are not indicated above. Please contact us for details.

| 記号 SYSTEM SYSTEM SISTEMA 型號 | 他社記号 OTHER MAKER SYSTEM PARALLELSYSTEME SISTEMAS EQUIVALENTES 其他公司型號 | 先端 POINT SPITZE PUNTA 針尖 | ミシン針イラスト ILLUSTRATION OF NEEDLE NADELFOTO FOTO DE AGUJA 縫紉機針示意圖 | 用途 APPLICATION ANMERKUNG NOTAS 用途 | 番手 NEEDLE SIZES NADELSTÄRKEN TAMAÑOS DE AGUJAS 針號 |
|---|--|--------------------------------------|---|---|---|
| TQ × 7 | 29 - L 175 × 7 2091 | | | A:1.75 D:47.00 N:17.50 ボタン付け button sewing | 9 10 11 12 13 14 16 18 19 20 21 22 23 24 65 70 75 80 85 90 100 110 120 125 130 140 160 190 |
| TQ × 7KK | | | | A:1.75 D:47.00 N:11.50 N寸短 shorter shank | 10 12 14 16 18 19 20 21 22 70 80 90 100 110 120 125 130 140 |
| TQ × 9 | 29 - LSS 175 × 9 | | | A:1.75 D:47.00 N:14.00~10.00 ボタン付け button sewing | 9 10 11 12 14 16 18 19 20 21 22 65 70 75 80 90 100 110 120 125 130 140 |
| TQ × 13 | 175 × 13 | | | A:1.75 D:50.00 N:14.00 ボタン付け button sewing | 13 16 18 20 22 85 100 110 125 140 |
| SM × 332LG | 332LGHKSP | | | A:1.98 D:48.50 N:18.00 ボタン付け button sewing | 11 12 14 16 18 19 21 22 23 75 80 90 100 110 120 130 140 160 |
| SM × 332EXTLG | 332EXT LG | | | A:1.98 D:54.50 N:18.00 ボタン付け button sewing | 9 10 11 12 14 16 18 65 70 75 80 90 100 110 |
| SM × 332EXTLG- NY | | | | A:1.98 D:54.50 N:18.00 強度対策針 SM × 332EXTLG with reinforced blade | 11 12 14 16 18 75 80 90 100 110 |
| SM × 332SUPLG | | | | A:1.98 D:59.50 N:18.00 ボタン付け button sewing | 12 14 16 80 90 100 |
| DP - N29 | | | | A:2.00 D:39.00 N:10.00 ボタン付け DP × 17 N寸短 button sewing DP×17 with shorter shank | 11 14 16 18 75 90 100 110 |
| DP × 17KK | | | | A:2.00 D:39.00 N:11.50 ボタン付け DP × 17 N寸短 button sewing DP×17 with shorter shank | 11 14 75 90 |







■ 千鳥縫い関係(穴かがり、閉止用) For Zigzag stitching, Buttonholing and Bartacking 曲折縫 鎖眼 套結系列

| | | | | | |
|----------|------------------------|--|--|---|--|
| DP × 5 | 134R 135 × 5 797 | | | A:2.00 D:33.90 N:12.50~11.50 穴かがり・千鳥縫用 buttonholing, zigzag stitching | 7 8 9 10 11 12 13 14 16 18 19 20 21 22 22½ 23 23½ 24 25 55 60 65 70 75 80 85 90 100 110 120 125 130 140 150 160 170 180 200 |
| DP × 5KN | | | | A:2.00 D:33.90 N:12.50 地糸切れ対策針 preventing fabric yarn breakage | 8 9 10 11 12 60 65 70 75 80 |
| DP × 5SF | | | | A:2.00 D:33.90 N:12.50 地糸切れ対策針 preventing fabric yarn breakage | 9 10 11 65 70 75 |
| DP × 5NS | | | | A:2.00 D:33.90 N:12.50~11.50 パッカリング対策 糸引け対策針 preventing seam puckering preventing needle line | 8 9 10 11 12 14 60 65 70 75 80 90 |

上記以外にも様々な種類の針があります。詳しくは、お問い合わせください。/ Please Note: we have many other types of needles that are not indicated above. Please contact us for details.

| 記号 SYSTEM SYSTEM SISTEMA 型號 | 他社記号 OTHER MAKER SYSTEM PARALLELSYSTEME SISTEMAS EQUIVALENTES 其他公司型號 | 先端 POINT SPITZE PUNTA 針尖 | ミシン針イラスト ILLUSTRATION OF NEEDLE NADEL FOTO FOTO DE AGUJA 縫紉機針示意图 | 用途 APPLICATION ANMERKUNG NOTAS 用途 | 番手 NEEDLE SIZES NADELSTÄRKEN TAMAÑOS DE AGUJAS 針號 |
|---|--|--------------------------------------|--|---|--|
| DP × 134 - NY2 | | | A:2.00 D:33.90 N:13.50~11.50 | DP×5の目飛び対策針 DP×5 with preventing skipped stitches | 9 10 11 12 14 16 18 19 20 21 22 23 65 70 75 80 90 100 110 120 125 130 140 160 |
| DP × 134 - SK1 | | | A:2.00 D:33.90 N:13.50~11.50 | 目飛び対策針 従来名称: DP×134-SK1 preventing skipped stitches former system:DP×134-SK1 | 14 16 18 19 20 21 22 23 90 100 110 120 125 130 140 160 |
| DP × 134HS | | | A:2.00 D:33.90 N:13.50~11.50 | 熱対策針 preventing needle heat | 10 11 12 14 16 18 22 70 75 80 90 100 110 140 |
| PF × 134KK | | | A:2.00 D:33.90 N:11.50 | DP × 5のN寸短 DP × 5 with shorter shank | 8 10 11 12 13 14 16 18 19 21 22 60 70 75 80 85 90 100 110 120 130 140 |
| DP × 1 | 135 × 1 354 | | A:2.00 D:31.90 N:12.50~11.50 | 本縫い lockstitch | 8 9 10 11 12 13 14 16 18 19 20 21 22 22z 23 24 25 60 65 70 75 80 85 90 100 110 120 125 130 140 150 160 180 200 |
| DP × 58 | | | A:2.00 D:33.90 N:12.50~11.50 | 千鳥縫用 zigzag stitching | 9 10 11 12 14 16 18 19 65 70 75 80 90 100 110 120 |
| DP × 265 | 265 - 50EO 438 - 80EO | | A:2.00 D:34.00 N:13.50 | ファンデーション用 for underwear | 10 11 12 14 16 18 19 70 75 80 90 100 110 120 |
| DP × 438 | 265 438 | | A:2.00 D:33.90 N:13.50 | 本縫千鳥用 lockstitch, zigzag stitching | 8 9 10 11 12 14 16 18 19 60 65 70 75 80 90 100 110 120 |
| DP × 438KK | | | A:2.00 D:33.90 N:11.50 | DP × 438のN寸短 DP × 438 with shorter shank | 10 12 14 16 18 19 70 80 90 100 110 120 |
| DP - G65 | | | A:2.00 D:33.90 N:12.50 | ファンデーション用(DP ×5 スリムUボール) for underwear (DP ×5 with slim U-ball point) | 9 10 11 65 70 75 |
| DP × 134LE | | | A:2.00 D:33.90 N:13.50~11.50 | 飾りステッチ用(DP ×5 糸穴大) decoration stitch(DP×5 with large needle eye) | 9 10 11 12 14 16 18 19 20 21 22 23 65 70 75 80 90 100 110 120 125 130 140 160 |
| SG × 1906 | 135 × 53 SY1906 | | A:2.00 D:33.90 N:13.50~11.50 | 千鳥縫用 ファンデーション用 zigzag stitching, for underwear | 8 9 10 11 12 13 14 16 18 19 20 21 60 65 70 75 80 85 90 100 110 120 125 130 |
| SG × 1963 | SY1963 | | A:2.00 D:33.90 N:13.50 | 千鳥縫用 ファンデーション用 zigzag stitching, for underwear | 8 9 10 11 12 60 65 70 75 80 |
| SG × 1965 | SY1965 | | A:2.00 D:33.90 N:13.50 | 千鳥縫用 ファンデーション用 zigzag stitching, for underwear | 9 10 11 12 14 65 70 75 80 90 |
| DO × 5 | 142 × 5 SY1413 | | A:2.02 D:31.30 N:10.00 | 鳩目穴かがり用 eyelet buttonholing | 11 12 14 16 18 19 20 21 22 75 80 90 100 110 120 125 130 140 |
| DO × 5 - NY | | | A:2.02 D:31.30 N:10.00 | 強度対策針 DO × 5 with reinforced blade | 16 18 19 100 110 120 |
| DO × 558 | 558 | | A:2.00 D:33.90 N:11.00 | 鳩目穴かがり用 eyelet buttonholing | 10 11 12 14 16 18 19 21 70 75 80 90 100 110 120 130 |
| DO × 558- NY2 | | | A:2.00 D:33.90 N:11.00 | 目飛び対策針 preventing skipped stitches | 12 14 16 18 19 80 90 100 110 120 |

上記以外にも様々な種類の針があります。詳しくは、お問い合わせください。/ Please Note: we have many other types of needles that are not indicated above. Please contact us for details.

| 記号 SYSTEM SYSTEM SISTEMA 型號 | 他社記号 OTHER MAKER SYSTEM PARALLELSYSTEME SISTEMAS EQUIVALENTES 其他公司型號 | 先端 POINT SPITZE PUNTA 針尖 | マシン針イラスト ILLUSTRATION OF NEEDLE NADELFOTO FOTO DE AGUJA 縫紉機針示意圖 | 用途 APPLICATION ANMERKUNG NOTAS 用途 | 番手 NEEDLE SIZES NADELSTÄRKEN TAMAÑOS DE AGUJAS 針號 |
|---|--|---|---|---|--|
| EB × 750 | 750(SC) |  |  A:1.62 D:33.20 N:12.50 | 穴かがり閉止用 buttonholing, bartacking | 8 9 10 11 12 14 16 18 19 20 21 22 60 65 70 75 80 90 100 110 120 125 130 140 |
| EB × 755 | 501(SC) 755H 1807 1807D |  |  A:1.62 D:33.00 N:12.00 | 鳩目穴かがり用 eyelet buttonholing | 8 9 10 11 12 14 16 18 19 20 21 23 60 65 70 75 80 90 100 110 120 125 130 160 |
| EB × 755NS | |  |  A:1.62 D:33.00 N:12.00 | 新合繊用 for new synthetic materials | 11 12 14 75 80 90 |
| | | | | | |

■ 二重環縫い関係 For Double chainstitch 雙鏈縫系列

| | | | | | |
|----------------|----------------------------------|---|---|---|---|
| DV × 1 | UY121GS 759 1628 MY1001 |  |  A:2.00 D:39.00 N:13.50 (E:46.00~43.70) | 平2本二重環縫用 2-needle double chainstitch | 7 8 9 10 11 12 13 14 16 18 19 20 21 22 23 24 25 55 60 65 70 75 80 85 90 100 110 120 125 130 140 160 180 200 |
| DV × 43 | 62 × 43 |  |  A:2.00 D:39.00 N:13.50 (E:44.90~44.70) | 二重環縫用 #19以上=TV × 3 double chainstitch over#19=TV × 3 | 9 10 11 12 13 14 16 18 65 70 75 80 85 90 100 110 |
| DV × G9 | |  |  A:2.00 D:39.00 N:13.50 (E:44.80~44.50) | DV × 43 エグリ付き DV × 43 with scarf | 8 9 11 12 13 14 60 65 75 80 85 90 |
| DV × 57 | 62 × 57 5640 |  |  A:2.00 D:38.60 N:13.00 (E:44.20) | 厚物二重環縫用 溝ひねり針 for thick materials (twist groove) | 9 10 11 12 13 14 16 18 19 20 21 22 22½ 23 24 25 65 70 75 80 85 90 100 110 120 125 130 140 150 160 180 200 |
| DV × 57 - NY2 | |  |  A:2.00 D:38.60 N:13.00 (E:44.20) | 目飛び対策針 preventing skipped stitches | 18 19 20 21 22 110 120 125 130 140 |
| DV × 57LE | |  |  A:2.00 D:38.70 N:13.00 (E:44.70) | 糸穴大 large needle eye | 16 18 19 20 21 22 24 100 110 120 125 130 140 180 |
| DV × 57LE- NY2 | |  |  A:2.00 D:38.60 N:13.00 (E:44.20) | 目飛び対策針 preventing skipped stitches | 18 19 110 120 |
| DV × 59 | 62 × 59 |  |  A:2.00 D:41.50 N:13.00 (E:48.50) | 厚物二重環縫用 溝ひねり針 for thick materials (twist groove) | 14 16 18 19 20 21 22 23 24 25 90 100 110 120 125 130 140 160 180 200 |
| DV × 210 | |  |  A:2.00 D:49.00 N:13.00(E:56.00) | キルティング用 for quilting | 21 22 23 24 130 140 160 180 |
| DV × 600 | |  |  A:2.00 D:54.00 N:20.00~17.00(E:63.00) | キルティング用 for quilting | 14 18 21 23 24 90 110 130 160 180 |
| DV × 63 | B - 63 |  |  A:2.00 D:39.00 N:13.50 (E:43.70) | 2~3本針二重環縫用 2 or 3-needle double chainstitch | 7 8 9 10 11 12 13 14 16 18 19 20 21 22 23 55 60 65 70 75 80 85 90 100 110 120 125 130 140 160 |
| UY × 128GAS | UY128GAS MY1040 |  |  A:2.00 D:39.00 N:14.50~13.50 (E:44.80~44.60) | 平2~3本針 2 or 3-needle double chainstitch | 7 8 9 10 11 12 13 14 16 18 19 20 21 22 22½ 23 23½ 25 55 60 65 70 75 80 85 90 100 110 120 125 130 140 150 160 170 200 |

上記以外にも様々な種類の針があります。詳しくは、お問い合わせください。/ Please Note: we have many other types of needles that are not indicated above. Please contact us for details.

| 記号 SYSTEM SYSTEM SISTEMA 型號 | 他社記号 OTHER MAKER SYSTEM PARALLELSYSTEME SISTEMAS EQUIVALENTES 其他公司型號 | 先端 POINT SPITZE PUNTA 針尖 | ミシン針イラスト ILLUSTRATION OF NEEDLE NADEL FOTO FOTO DE AGUJA 縫紉機針示意图 | 用途 APPLICATION ANMERKUNG NOTAS 用途 | 番手 NEEDLE SIZES NADELSTÄRKEN TAMAÑOS DE AGUJAS 針號 |
|---|--|--------------------------------------|--|--|---|
| UY × 128GASKN | | | A:2.00 D:39.00 N:14.50 (E:44.80~44.60) | 地糸切れ対策針 preventing fabric yarn breakage | 7 8 9 10 11 12 55 60 65 70 75 80 |
| UY × 128KK | | | A:2.00 D:39.00 N:12.00 (E:44.70) | UY × 128GASのN寸短 UY × 128GAS with short shank | 7 8 9 10 11 55 60 65 70 75 |
| UY × 128KK - KN | | | A:2.00 D:39.00 N:12.00 (E:44.60~44.80) | UY × 128GASKNのN寸短 UY × 128GASKN with short shank | 7 8 9 10 11 55 60 65 70 75 |
| UY × 128GAS - NY2 | | | A:2.00 D:39.00 N:14.50 (E:44.70) | 目飛び対策針 preventing skipped stitches | 7 8 9 10 11 12 14 16 18 19 20 21 22 55 60 65 70 75 80 90 100 110 120 125 130 140 |
| UY × 128GAS - SK1 | | | A:2.00 D:39.00 N:14.50~13.50 (E:44.70) | 目飛び対策針 従来名称:UY×128GAS-SK1 preventing skipped stitches former system:UY×128GAS-SK1 | 14 16 18 19 20 21 90 100 110 120 125 130 |
| UY × 128LE | | | A:2.00 D:39.00 N:14.50 (E:44.70) | UY × 128GASの糸穴大 UY × 128GAS with large needle eye | 8 9 10 11 12 14 16 18 19 21 23 60 65 70 75 80 90 100 110 120 130 160 |
| UY × 128FL | | | A:2.00 D:39.00 N:14.50 (E:44.70) | UY × 128GASの平取針 UY × 128GAS with flat shank | 8 9 10 60 65 70 |
| DV - C65 | | | A:2.00 D:39.00 N:14.50 (E:44.70) | UY × 128GASの平取針 UY × 128GAS with flat shank | 8 9 10 11 60 65 70 75 |
| TV × 1 | 149 × 1 | | A:2.00 D:37.00 N:13.50 (E:41.90~41.60) | へム縫、伏せ縫用 hemming, felled seam | 7 8 9 10 11 12 13 14 16 18 19 20 21 22 23 55 60 65 70 75 80 85 90 100 110 120 125 130 140 160 |
| TV × 3 | 149 × 3 UY124GS | | A:2.00 D:39.00 N:13.50 (E:45.00) | 脇縫用 #18以下=DV×43 for side seam #18 and under=DV×43 | 19 20 21 22 23 24 120 125 130 140 160 180 |
| TV × 5 | 149 × 5 62 × 53 | | A:2.00 D:41.40 N:13.50 (E:47.40~46.50) | 伏せ縫用 felled seam | 8 9 10 11 12 13 14 16 18 19 20 21 22 23 24 25 60 65 70 75 80 85 90 100 110 120 125 130 140 160 180 200 |
| TV × 5 - SK | | | A:2.00 D:41.40 N:13.50 (E:46.70) | 目飛び対策針 従来名称:TV×5-SK2 preventing skipped stitches former system:TV×5-SK2 | 12 80 |
| TV × 5HS | | | A:2.00 D:41.40 N:13.50 (E:47.20~47.00) | 熱対策針 preventing needle heat | 18 19 21 110 120 130 |
| TV × 7 | 149 × 7 MY1002A | | A:2.00 D:37.00 N:13.50 (E:42.80~42.50) | へム縫、伏せ縫用 hemming, felled seam | 8 9 10 11 12 13 14 16 17 18 19 20 21 22 23 24 25 60 65 70 75 80 85 90 100 105 110 120 125 130 140 160 180 200 |
| TV × 7HS | | | A:2.00 D:37.00 N:13.50 (E:42.80~42.30) | 熱対策針 preventing needle heat | 14 16 18 90 100 110 |
| TV × 64 | B - 64 | | A:2.00 D:36.60 N:13.50 (E:41.60~41.10) | 伏せ縫用 felled seam | 8 9 10 11 12 13 14 16 18 19 20 21 22 23 25 60 65 70 75 80 85 90 100 110 120 125 130 140 160 200 |
| UO × 113GS | UY113GS | | A:2.00 D:36.60 N:14.50~13.50 (E:41.50) | スマッキング等 二重環縫い smocking, double chainstitch | 8 9 10 11 12 13 14 16 18 19 20 21 22 23 60 65 70 75 80 85 90 100 110 120 125 130 140 160 |
| UO × 113GS-NY2 | | | A:2.00 D:36.60 N:13.50 (E:41.50) | 目飛び対策針 preventing skipprd stitches | 14 90 |

上記以外にも様々な種類の針があります。詳しくは、お問い合わせください。/ Please Note: we have many other types of needles that are not indicated above. Please contact us for details.

| 記号 SYSTEM SYSTEM SISTEMA 型號 | 他社記号 OTHER MAKER SYSTEM PARALLELSYSTEME SISTEMAS EQUIVALENTES 其他公司型號 | 先端 POINT SPITZE PUNTA 針尖 | ミシン針イラスト ILLUSTRATION OF NEEDLE NADELFOTO FOTO DE AGUJA 縫紉機針示意图 | 用途 APPLICATION ANMERKUNG NOTAS 用途 | 番手 NEEDLE SIZES NADELSTÄRKEN TAMAÑOS DE AGUJAS 針號 |
|---|--|--------------------------------------|---|---|--|
| UO × 163 | UY163GAS | | A:2.00 D:37.50 N:13.50 (E:43.90) | ピコット縫用 for picot stitch | 8 9 10 11 12 13 14 16 18 19 21 22 22½ 60 65 70 75 80 85 90 100 110 120 130 140 150 |
| UO × 163GAS | UY163GAS SY7185 | | A:2.00 D:37.50 N:13.50 (E:43.90) | ピコット縫用 for picot stitch | 11 12 14 16 18 19 20 75 80 90 100 110 120 125 |
| UY × 121 | UY121GS MY1001 759 | | A:2.00 D:39.00 N:13.50 (E:43.70) | 平2本二重環縫用 2-needle double chainstitch | 7 8 9 10 11 12 13 14 16 18 19 20 21 22 23 55 60 65 70 75 80 85 90 100 110 120 125 130 140 160 |
| UY × 121GBS | UY121GBS | | A:2.00 D:39.00 N:14.50~13.50 (E:43.70) | 平2本二重環縫用 2-needle double chainstitch | 9 10 11 12 14 16 18 19 21 65 70 75 80 90 100 110 120 130 |
| SM × 1014A | MY1014A | | A:1.48 D:39.00 N:15.50 (E:44.20) | 4本針偏平縫用 4-needle interlock stitch | 8 9 10 11 12 14 60 65 70 75 80 90 |
| SM × 1014B | MY1014B | | A:1.48 D:39.00 N:15.50 (E:44.20) | 4本針偏平縫用 エグリ付き 4-needle interlock stitch (with scarf) | 8 9 10 11 12 14 16 18 60 65 70 75 80 90 100 110 |
| SM × 1014H | MY1014H | | A:1.48 D:39.00 N:15.50 (E:43.80) | 4本針偏平縫用 目飛び対策針 4-needle interlock stitch preventing skipped stitches | 9 10 11 12 65 70 75 80 |

■ フラットシーマー関係 For Flat seamer 多針鏈縫系列

| | | | | | |
|-------------------|----------|--|----------------------------------|--|--|
| FL × 118A | UY118GAS | | A:1.51 D:36.60 N:16.50 | フラットシーマー flat seamer | 8 9 10 11 12 14 16 18 60 65 70 75 80 90 100 110 |
| FL × 118GBS | UY118GBS | | A:1.51 D:36.60 N:16.50 | フラットシーマー flat seamer | 8 9 10 11 12 14 16 60 65 70 75 80 90 100 |
| FL × 118GCS | UY118GKS | | A:1.51 D:36.60 N:16.50 | フラットシーマー エグリ付き flat seamer with scarf | 8 9 10 11 12 60 65 70 75 80 |
| FL × 118GCS - NY2 | | | A:1.51 D:36.60 N:16.50 | FL × 118GCSの目飛び対策針 FL × 118GCS preventing skipped stitches | 9 10 11 65 70 75 |
| FL × 118GCSSF | | | A:1.51 D:36.60 N:16.50 | 地糸切れ対策針 preventing fabric yarn breakage | 9 10 11 65 70 75 |
| FL × 118KK | | | A:1.51 D:36.60 N:15.50 | FL × 118GCSのN寸短 FL × 118GCS with short shank | 9 10 11 65 70 75 |
| FL × 118 - SK2 | | | A:1.51 D:36.60 N:16.50 | 目飛び対策針 従来名称: FL×118-SK2 preventing skipped stitches former system: FL×118-SK2 | 8 9 10 11 60 65 70 75 |
| FLG - 1 | | | A:1.51 (E:41.20) N:15.00 | フラットシーマー リテーナ針 retainer needle | 7 8 9 10 11 12 55 60 65 70 75 80 |
| FLG - 8 | | | A:1.51 (E:41.20) N:15.00 | フラットシーマー リテーナ針エグリ付 retainer needle with scarf | 8 60 |

上記以外にも様々な種類の針があります。詳しくは、お問い合わせください。/ Please Note: we have many other types of needles that are not indicated above. Please contact us for details.

| | | | | | |
|---|--|--------------------------------------|--|---|---|
| 記号 SYSTEM SYSTEM SISTEMA 型號 | 他社記号 OTHER MAKER SYSTEM PARALLELSYSTEME SISTEMAS EQUIVALENTES 其他公司型號 | 先端 POINT SPITZE PUNTA 針尖 | ミシン針イラスト ILLUSTRATION OF NEEDLE NADEL/FOTO FOTO DE AGUJA 縫紉機針示意图 | 用途 APPLICATION ANMERKUNG NOTAS 用途 | 番手 NEEDLE SIZES NADELSTÄRKEN TAMAÑOS DE AGUJAS 針號 |
|---|--|--------------------------------------|--|---|---|

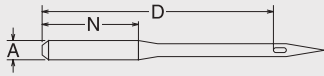







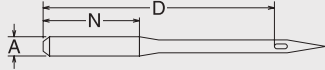







■ オーバーロック関係 For Overlock 包縫系列

| | | | | | | |
|------------|--------------------------|--|--|------------------------------|--|---|
| DC × 1 | 81 × 1 MY1023A 621 | | | A:2.02 D:28.60 N:10.00 | オーバーロック用 overlock (～#11=J ball) | 6 7 8 9 10 11 12 13 14 16 18 19 20 21 22 23 24 25 50 55 60 65 70 75 80 85 90 100 110 120 125 130 140 160 180 200 |
| DC × 1NS | | | | A:2.02 D:28.60 N:10.00 | パッカリング対策 preventing seam puckering | 8 9 10 11 12 60 65 70 75 80 |
| DC × 1KN | | | | A:2.02 D:28.60 N:10.00 | 地糸切れ対策針 preventing fabric yarn breakage | 8 9 10 11 12 14 60 65 70 75 80 90 |
| DC × 1SF | | | | A:2.02 D:28.60 N:10.00 | 地糸切れ対策針 preventing fabric yarn breakage | 8 9 10 11 60 65 70 75 |
| DC × 3 | SY8358 | | | A:1.22 D:28.50 N:13.00 | まつり縫い用 2本針オーバーロック blind stitch, 2-needle overlock | 7 8 9 10 11 12 13 14 16 18 19 20 21 22 55 60 65 70 75 80 85 90 100 110 120 125 130 140 |
| DC × 3KN | | | | A:1.22 D:28.60 N:13.00 | 地糸切れ対策針 preventing fabric yarn breakage | 9 10 11 65 70 75 |
| DC × 27 | B - 27 MY1023 | | | A:2.02 D:28.60 N:10.00 | 1～3本針オーバーロック用 1to3-needle overlock (～#11=J ball) | 6 7 8 9 10 11 12 13 14 16 18 19 20 21 22 23 24 50 55 60 65 70 75 80 85 90 100 110 120 125 130 140 160 180 |
| DC - C47 | | | | A:2.02 D:28.60 N:10.00 | 両面平取 flat shank on both sides | 9 10 11 12 13 16 18 65 70 75 80 85 100 110 |
| DC × 27LE | | | | A:2.02 D:28.60 N:10.00 | 糸穴大 糸締め不良対策 large needle eye preventing loose seams | 11 12 14 16 75 80 90 100 |
| DC - N17 | 81 × 1 621 MY1023A | | | A:2.02 D:28.60 N:13.00 | DC × 1N寸=13mm shank length = 13mm | 7 8 9 10 11 12 13 14 16 18 19 20 21 22 55 60 65 70 75 80 85 90 100 110 120 125 130 140 |
| DC - N17SF | | | | A:2.02 D:28.60 N:13.00 | 地糸切れ対策針 preventing fabric yarn breakage | 9 10 65 70 |
| DC - N24 | | | | A:2.02 D:28.60 N:13.00 | DC × 27N寸=13mm shank length = 13mm | 11 14 75 90 |
| DC - N25 | | | | A:2.02 D:28.60 N:11.50 | DC × 1N寸=11.50mm shank length = 11.50mm | 7 8 9 10 11 55 60 65 70 75 |
| DC - N25SF | | | | A:2.02 D:28.60 N:11.50 | 地糸切れ対策針 preventing fabric yarn breakage | 9 65 |
| DM × 13 | 82 × 13 1886KK | | | A:2.02 D:28.60 N:8.00 | DC × 1のN寸短 DC × 1 with shorter shank (～#11=J ball) | 7 8 9 10 11 12 13 14 16 18 19 20 21 22 23 24 55 60 65 70 75 80 85 90 100 110 120 125 130 140 160 180 |
| DM × 13KN | | | | A:2.02 D:28.60 N:8.00 | DC × 1KNのN寸短 DC × 1KN with shorter shank | 9 10 11 65 70 75 |

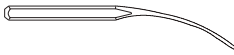
上記以外にも様々な種類の針があります。詳しくは、お問い合わせください。/ Please Note: we have many other types of needles that are not indicated above. Please contact us for details.

| | | | | | | |
|---|--|--------------------------------------|---|--|---|---|
| 記号 SYSTEM SYSTEM SISTEMA 型號 | 他社記号 OTHER MAKER SYSTEM PARALLELSYSTEME SISTEMAS EQUIVALENTES 其他公司型號 | 先端 POINT SPITZE PUNTA 針尖 | ミシン針イラスト ILLUSTRATION OF NEEDLE NADELFOTO FOTO DE AGUJA 縫紉機針示意图 |  | 用途 APPLICATION ANMERKUNG NOTAS 用途 | 番手 NEEDLE SIZES NADELSTÄRKEN TAMAÑOS DE AGUJAS 針號 |
|---|--|--------------------------------------|---|--|---|---|

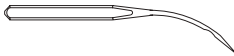

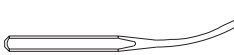







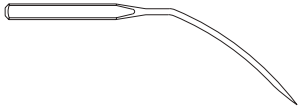

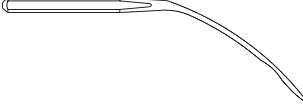
■ 曲げ針オーバーロック関係 For Curved overlock needle 彎針包縫系列

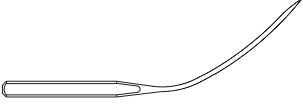
| | | | | | | |
|-------------|--------------------|---|---|------------------------------|---|---|
| UN × 154 | UY8454GS |  |  | A:2.02 D:31.40 N:14.50 | 曲針オーバーロック curved overlock needle | 7 8 9 10 11 12 13 14 16 18 21 55 60 65 70 75 80 85 90 100 110 130 |
| UN - R7 | |  |  | A:2.02 D:31.40 N:14.50 | 曲針オーバーロック 両面平取 curved overlock needle (flat shank on both sides) | 9 11 14 65 75 90 |
| UN - R12 | |  |  | A:2.02 D:31.40 N:14.50 | 曲針オーバーロック 両面平取 curved overlock needle (flat shank on both sides) | 9 11 14 65 75 90 |
| UO × 154 | |  |  | A:2.02 D:31.40 N:14.50 | 曲針オーバーロック curved overlock needle | 7 8 9 10 11 12 13 14 16 18 19 20 22 55 60 65 70 75 80 85 90 100 110 120 125 140 |
| UY × 154GAS | UY154GAS SY1431 |  |  | A:2.02 D:31.60 N:14.50 | 曲針オーバーロック 片面平取 curved overlock needle (flat shank on one side) | 7 8 9 10 11 12 14 16 18 19 20 21 22 55 60 65 70 75 80 90 100 110 120 125 130 140 |
| UY × 154GBS | UY154GBS SY6430 |  |  | A:2.02 D:31.60 N:14.50 | 曲針オーバーロック 片面平取 curved overlock needle (flat shank on one side) | 9 10 11 12 14 16 18 65 70 75 80 90 100 110 |
| UY × 154GCS | UY154GCS SY6431 |  |  | A:2.02 D:31.60 N:14.50 | 曲針オーバーロック 両面平取 curved overlock needle (flat shank on both sides) | 9 10 11 12 14 16 65 70 75 80 90 100 |
| MR - R9 | |  |  | A:2.03 D:29.20 N:15.00 | メローオーバーロック用 for merrow overlock | 8 9 10 11 12 13 14 16 18 19 21 22½ 60 65 70 75 80 85 90 100 110 120 130 150 |
| | | | | | | |
| | | | | | | |

■ マツリ、スクイ縫い関係 For Blind stitch 暗縫系列

| | | | | | | |
|---------|--------------|---|---|------------------------------|--|--|
| LW × 1T | 29 - 12 |  |  | A:2.02 D:36.20 N:10.00 | 伏せ縫 マツリ縫用 felled seam, blind stitch | 8 9 10 11 12 14 16 18 19 21 60 65 70 75 80 90 100 110 120 130 |
| LW × 2T | 29 - 34 |  |  | A:2.02 D:39.90 N:15.00 | 伏せ縫 マツリ縫用 felled seam, blind stitch | 8 9 10 11 12 13 14 16 18 19 21 60 65 70 75 80 85 90 100 110 120 130 |
| LW × 3T | 29 - C - 300 |  |  | A:2.02 D:38.70 N:15.50 | 盲縫 マツリ縫用 blind stitch | 8 9 10 11 12 13 14 16 18 19 20 21 22 60 65 70 75 80 85 90 100 110 120 125 130 140 |







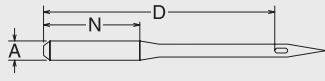











上記以外にも様々な種類の針があります。詳しくは、お問い合わせください。/ Please Note: we have many other types of needles that are not indicated above. Please contact us for details.

| 記号 SYSTEM SYSTEM SISTEMA 型號 | 他社記号 OTHER MAKER SYSTEM PARALLELSYSTEME SISTEMAS EQUIVALENTES 其他公司型號 | 先端 POINT SPITZE PUNTA 針尖 | ミシン針イラスト ILLUSTRATION OF NEEDLE NADELFOTO FOTO DE AGUJA 縫紉機針示意圖 | 用途 APPLICATION ANMERKUNG NOTAS 用途 | 番手 NEEDLE SIZES NADELSTÄRKEN TAMAÑOS DE AGUJAS 針號 |
|---|--|---|---|---|--|
| LW × 4T | 29 - C - 300 |  |  A:2.02 D:38.70 N:15.50 | 盲縫 マツリ縫用 blind stitch | 8 9 11 12 14 16 60 65 75 80 90 100 |
| LW × 5T | 29 - C - 300LG |  |  A:2.02 D:40.70 N:15.50 | 奥マツリ用 blind stitch | 0 5 10 15 20 25 30 35 40 45 50 65 70 75 80 85 90 95 100 105 110 120 |
| LW × 6T | 29 - 34 |  |  A:2.02 D:40.00 N:15.00 | 伏せ縫 マツリ縫用 felled seam, blind stitch | 7 8 9 10 11 12 13 14 16 18 19 1½ 2 2½ 3 3½ 4 4½ 5 55 60 65 70 75 80 85 90 100 110 120 |
| LW × 251EU | 251EU |  |  A:2.02 D:38.90 N:14.50 | 盲縫 マツリ縫用 blind stitch | 8 9 10 11 12 14 15 16 18 60 65 70 75 80 90 100 110 |
| LW × 1669E | 1669E |  |  A:2.02 D:38.90~38.60 N:13.50 | ハザシ用 for lapel padding and collar | 8 9 10 11 12 13 14 16 18 19 21 60 65 70 75 80 85 90 100 110 120 130 |
| LW × 1669E EO | 1669E EO |  |  A:2.02 D:38.60 N:14.00 | ハザシ用 for lapel padding and collar | 8 9 10 12 14 16 60 65 70 80 90 100 |
| LW - C5 | 29 - 39 |  |  A:2.02 D:36.20 N:10.00 | 伏せ縫 マツリ縫用 felled seam, blind stitch LW × 1 Tの逆平取針 | 8 9 10 11 12 14 16 18 19 21 60 65 70 75 80 90 100 110 120 130 |
| | | | | | |
| | | | | | |
| | | | | | |
| | | | | | |

上記以外にも様々な種類の針があります。詳しくは、お問い合わせください。／ Please Note: we have many other types of needles that are not indicated above. Please contact us for details.

| | | | | | | |
|---|--|--------------------------------------|---|--|---|---|
| 記号 SYSTEM SYSTEM SYSTEM SISTEMA 型號 | 他社記号 OTHER MAKER SYSTEM PARALLELSYSTEME SISTEMAS EQUIVALENTES 其他公司型號 | 先端 POINT SPITZE PUNTA 針尖 | マシン針イラスト ILLUSTRATION OF NEEDLE NADELFOTO FOTO DE AGUJA 縫紉機針示意图 |  | 用途 APPLICATION ANMERKUNG NOTAS 用途 | 番手 NEEDLE SIZES NADELSTÄRKEN TAMAÑOS DE AGUJAS 針號 |
|---|--|--------------------------------------|---|--|---|---|

■ ハンドステッチ関係 For Hand stitch 仿手工縫系列

| | | | | | | |
|-------------|-----------------------------|---|---|------------------------------|---|--|
| CP × 1 | 29 - C - 150 SY1902 |  |  | A:2.02 D:34.50 N:18.00 | 星飾り縫い・ピンポイント用 pinpoint and decoration stitch | 12 14 16 18 19 21 22 80 90 100 110 120 130 140 |
| CP × 1J | |  |  | A:2.02 D:34.50 N:18.00 | 星飾り縫い・ピンポイント用 pinpoint and decoration stitch | 14 16 18 19 21 22 90 100 110 120 130 140 |
| CP × 2 | |  |  | A:2.02 D:34.50 N:14.00 | 星飾り縫い・ピンポイント用 pinpoint and decoration stitch | 14 16 18 19 21 22 23 90 100 110 120 130 140 160 |
| CP × 12 | 29 - C - 151 151 151S |  |  | A:2.02 N:18.00 | 星飾り縫い・ピンポイント用 pinpoint and decoration stitch | 11 12 14 16 18 19 20 21 22 23 75 80 90 100 110 120 125 130 140 160 |
| CP × 12J | |  |  | A:2.02 N:18.00 | 星飾り縫い・ピンポイント用 pinpoint and decoration stitch | 19 20 21 22 23 120 125 130 140 160 |
| CP × 13 | |  |  | A:2.02 N:14.00 | 星飾り縫い・ピンポイント用 pinpoint and decoration stitch | 9 11 12 14 16 18 19 20 21 22 23 65 75 80 90 100 110 120 125 130 140 160 |
| CP × 17 | |  |  | A:2.02 N:12.50 | 星飾り縫い・ピンポイント用 pinpoint and decoration stitch | 11 14 16 18 19 21 75 90 100 110 120 130 |
| CP × 170 | |  |  | A:2.02 N:12.50 | 星飾り縫い・ピンポイント用 pinpoint and decoration stitch | 14 16 18 19 21 90 100 110 120 130 |
| CP × 200 | |  |  | A:2.02 D:34.50 N:14.00 | 星飾り縫い・ピンポイント用 pinpoint and decoration stitch | 14 16 18 19 90 100 110 120 |
| DPN - 1032B | | |  | A:1.00 (E:44.40) | ハンドステッチ用 for hand stitch | 32 38 49 80 100 115 |

■ レザー針関係 For Leather 皮革系列





























* 記号を変更いたしましたのでご注意ください
* Please Note: we have renamed the system.
* 種類名稱已經更改,敬請注意。

| | | | | | | |
|------------|-----------|---|---|------------------------------------|---|---|
| DP × 17LL* | 135x16TW |  |  | A:2.00 D:39.00 N:13.50~13.00 | 皮革用 従来名称: DPx16N for leather former system: DP × 16N | 20 21 22 23 24 125 130 140 160 180 |
| DP × 17LR* | 135x16RTW |  |  | A:2.00 D:39.00 N:16.00~13.00 | 皮革用 従来名称: DPx17LR/DPx16LR for leather former system: DP × 17LR/DP × 16LR | 14 16 18 19 20 21 22 23 24 90 100 110 120 125 130 140 160 180 |
| DP × 17S | |  |  | A:2.00 D:39.00 N:16.00~13.50 | 皮革用 for leather | 14 16 18 19 20 21 22 23 90 100 110 120 125 130 140 160 |
| DP × 17P* | 135x16NW |  |  | A:2.00 D:39.00 N:16.00~13.00 | 皮革用 従来名称: DPx16 for leather former system: DP × 16 | 12 14 16 18 19 20 21 22 23 24 25 80 90 100 110 120 125 130 140 160 180 200 |

上記以外にも様々な種類の針があります。詳しくは、お問い合わせください。/ Please Note: we have many other types of needles that are not indicated above. Please contact us for details.

| 記号 SYSTEM SYSTEM SISTEMA 型號 | 他社記号 OTHER MAKER SYSTEM PARALLELSYSTEME SISTEMAS EQUIVALENTES 其他公司型號 | 先端 POINT SPITZE PUNTA 針尖 | ミシン針イラスト ILLUSTRATION OF NEEDLE NADEL/FOTO FOTO DE AGUJA 縫紉機針示意图 | 用途 APPLICATION ANMERKUNG NOTAS 用途 | 番手 NEEDLE SIZES NADELSTÄRKEN TAMAÑOS DE AGUJAS 針號 |
|---|--|--------------------------------------|--|---|--|
| DP × 17DIA * | 135x16DIA | | A:2.00 D:39.00 N:16.00~13.00 | 皮革用 従来名称：DPx16DIA for leather former system：DP×16DIA | 16 18 19 20 21 22 23 24 25 100 110 120 125 130 140 160 180 200 |
| DP × 17TQ | | | A:2.00 D:39.00 N:16.00~13.00 | 皮革用 for leather | 14 16 18 19 21 22 23 90 100 110 120 130 140 160 |
| DP × 17LBR | | | A:2.00 D:39.00 N:13.00 | 皮革用 for leather | 23 160 |
| DP × 35LL | 134-35LL | | A:2.00 D:38.20 N:13.50 | 皮革用 for leather | 12 14 16 18 19 21 22 23 24 25 80 90 100 110 120 130 140 160 180 200 |
| DP × 35LR | 134-35LR | | A:2.00 D:38.20 N:13.50 | 皮革用 for leather | 10 12 13 14 16 18 19 20 21 22 22½ 23 24 25 26 70 80 85 90 100 110 120 125 130 140 150 160 180 200 230 |
| DP × 35S | | | A:2.00 D:38.20 N:13.50 | 皮革用 for leather | 14 16 18 19 21 22 23 90 100 110 120 130 140 160 |
| DP × 35P | | | A:2.00 D:38.20 N:13.50 | 皮革用 for leather | 10 12 14 16 19 21 22 70 80 90 100 120 130 140 |
| DP × 35D | | | A:2.00 D:38.20 N:13.50 | 皮革用 for leather | 14 16 18 19 21 22 22½ 23 24 90 100 110 120 130 140 150 160 180 |
| DP × 35PCL | 134-35PCL | | A:2.00 D:38.20 N:13.50 | 皮革用 for leather | 10 12 14 16 18 19 21 70 80 90 100 110 120 130 |
| DP × 134LL * | 134LL | | A:2.00 D:33.90 N:14.50~11.50 | 皮革用 従来名称：PFx134LL for leather former system：PF×134LL | 10 11 12 13 14 16 18 19 21 22 23 24 70 75 80 85 90 100 110 120 130 140 160 180 |
| DP × 134LR * | 134LR | | A:2.00 D:33.90 N:14.50~11.50 | 皮革用 従来名称：PFx134LR for leather former system：PF×134LR | 9 10 11 12 13 14 16 18 19 20 21 22 22½ 23 24 25 65 70 75 80 85 90 100 110 120 125 130 140 150 160 180 200 |
| DP × 134S * | 134S | | A:2.00 D:33.90 N:14.50~11.50 | 皮革用 従来名称：PFx134KS for leather former system：PF×134KS | 9 10 11 12 13 14 16 18 19 21 22 22½ 23 25 65 70 75 80 85 90 100 110 120 130 140 150 160 200 |
| DP × 134P * | 134P | | A:2.00 D:33.90 N:14.50~11.50 | 皮革用 従来名称：PFx134P for leather former system：PF×134P | 10 11 12 13 14 16 18 19 20 21 22 23 70 75 80 85 90 100 110 120 125 130 140 160 |
| DP × 134DIA * | 134DIA 135 x 8 | | A:2.00 D:33.90 N:14.50~11.50 | 皮革用 従来名称：DPx8 for leather former system：DP×8 | 10 12 14 16 18 19 20 21 22 23 24 70 80 90 100 110 120 125 130 140 160 180 |
| DP × 134D * | 134D | | A:2.00 D:33.90 N:14.50~11.50 | 皮革用 従来名称：PFx134D for leather former system：PF×134D | 10 11 12 13 14 16 18 19 20 21 22 22½ 23 24 25 70 75 80 85 90 100 110 120 125 130 140 150 160 180 200 |
| PF × 134KKLR | | | A:2.00 D:33.90 N:14.50~11.50 | 皮革用 DPx134LRのN寸短 for leather DP×134LR with short shank | 9 10 11 12 14 16 18 19 22 65 70 75 80 90 100 110 120 140 |
| PF × 134KKD | | | A:2.00 D:33.90 N:14.50~11.50 | 皮革用 DPx134DのN寸短 for leather DP×134D with short shank | 11 14 16 18 25 90 100 110 |
| PF × 134KKPCL | | | A:2.00 D:33.90 N:14.50~11.50 | 皮革用 PFx134PCLのN寸短 for leather PF×134PCL with short shank | 9 10 11 12 14 16 18 19 20 21 22 65 70 75 80 90 100 110 120 125 130 140 |







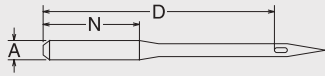



















上記以外にも様々な種類の針があります。詳しくは、お問い合わせください。/ Please Note: we have many other types of needles that are not indicated above. Please contact us for details.

| 記号 SYSTEM SYSTEM SISTEMA 型號 | 他社記号 OTHER MAKER SYSTEM PARALLELSYSTEME SISTEMAS EQUIVALENTES 其他公司型號 | 先端 POINT SPITZE PUNTA 針尖 | ミシン針イラスト ILLUSTRATION OF NEEDLE NADELFOTO FOTO DE AGUJA 縫紉機針示意圖 | 用途 APPLICATION ANMERKUNG NOTAS 用途 | 番手 NEEDLE SIZES NADELSTÄRKEN TAMAÑOS DE AGUJAS 針號 |
|---|--|---|---|---|---|
| PF × 134PCL | 134PCL |  |  A:2.00 D:33.90 N:14.50~11.50 | 皮革用 for leather | 8 9 10 11 12 13 14 16 18 19 20 21 22 22½ 23 24 25 60 65 70 75 80 85 90 100 110 120 125 130 140 150 160 180 200 |
| PF × 134PCR | 134PCR |  |  A:2.00 D:33.90 N:14.50~11.50 | 皮革用 for leather | 10 11 12 13 14 16 18 19 21 22 70 75 80 85 90 100 110 120 130 140 |
| PF × 134VR | |  |  A:2.00 D:33.90 N:14.50~11.50 | 皮革用 for leather | 14 16 18 19 21 22 90 100 110 120 130 140 |
| DP × F22 | 134KKS |  |  A:2.00 D:33.90 N:12.50~11.50 | 皮革用 for leather | 9 10 11 12 14 16 18 19 20 21 22 23 65 70 75 80 90 100 110 120 125 130 140 160 |
| PF × 34P | 34P |  |  A:1.62 D:34.00 N:13.50 | 皮革用 for leather | 10 11 12 13 14 16 18 70 75 80 85 90 100 110 |
| DB × F2 | 1738LR |  |  A:1.62~2.02 D:33.80 N:16.00~10.50 | 皮革用 for leather | 9 11 12 13 14 16 18 19 20 21 22 23 24 25 65 75 80 85 90 100 110 120 125 130 140 160 180 200 |
| DB-F42 | |  |  A:1.62 D:33.8 N:11.50~12.50 | 皮革用 for leather | 19 20 21 22 120 125 130 140 |
| DB × F17 | 1738S |  |  A:1.62~1.90 D:33.80 N:16.00~12.50 | 皮革用 for leather | 8 9 10 11 12 14 16 18 19 60 65 70 75 80 90 100 110 120 |
| TF × 2 | 34LL |  |  A:1.62/1.90/2.02 D:33.80 N:13.50~10.50 | 皮革用 for leather | 7 8 9 10 11 12 13 14 16 18 19 20 21 22 23 24 25 55 60 65 70 75 80 85 90 100 110 120 125 130 140 160 180 200 |
| TF × 2LR | 34LR |  |  A:1.62/1.90/2.02 D:33.80 N:13.50~10.50 | 皮革用 for leather | 7 8 9 10 11 12 13 14 16 18 19 20 21 22 23 24 25 55 60 65 70 75 80 85 90 100 110 120 125 130 140 160 180 200 |
| TF × 2D | 34DIA |  |  A:1.62/1.90/2.02 D:33.80 N:13.50~10.50 | 皮革用 for leather | 9 10 11 12 14 16 18 19 20 21 22 65 70 75 80 90 100 110 120 125 130 140 |
| TF × 4 | 34PCL |  |  A:1.62/1.90/2.02 D:33.8 N:13.50~11.00 | 皮革用 for leather | 8 9 10 11 12 13 14 16 18 19 20 21 60 65 70 75 80 85 90 100 110 120 125 130 |
| TF × 6 | 34PCR |  |  A:1.62/1.90/2.02 D:33.85 N:13.50~11.00 | 皮革用 for leather | 8 9 10 11 12 13 14 16 18 19 20 21 22 23 24 60 65 70 75 80 85 90 100 110 120 125 130 140 160 180 |
| TF × F8 | SY2078 34S |  |  A:1.62/1.90/2.02 D:33.80 N:13.50~10.50 | 皮革用 for leather | 7 8 9 10 11 12 14 16 18 19 21 22 55 60 65 70 75 80 90 100 110 120 130 140 |
| | | | | | |
| | | | | | |
| | | | | | |
| | | | | | |

上記以外にも様々な種類の針があります。詳しくは、お問い合わせください。／Please Note: we have many other types of needles that are not indicated above. Please contact us for details.

| | | | | | | |
|---|--|-------------------------------------|--|--|---|---|
| 記号 SYSTEM SYSTEM SISTEMA 型號 | 他社記号 OTHER MAKER SYSTEM PARALLELSYSTEME SISTEMAS EQUIVALENTES 其他公司型號 | 先端 POINT SPITZ PUNTA 針尖 | ミシン針イラスト ILLUSTRATION OF NEEDLE NADEL FOTO FOTO DE AGUJA 縫紉機針示意圖 |  | 用途 APPLICATION ANMERKUNG NOTAS 用途 | 番手 NEEDLE SIZES NADELSTÄRKEN TAMAÑOS DE AGUJAS 針號 |
|---|--|-------------------------------------|--|--|---|---|

■ 家庭用ミシン関係 For Home sewing machine 家庭用針系列

| | | | | | | | |
|----------|----------------------------------|---|---|------------------------------------|---|--|--|
| HA × 1 | 15 × 1 130/705H |  |  | A:2.02 D:33.80 N:11.70 | 家庭用ミシン針 for home sewing machine | 7 8 9 10 11 12 13 14 16 18 19 20 21 22 23 55 60 65 70 75 80 85 90 100 110 120 125 130 140 160 | |
| HA × 1DE | |  |  | A:2.02 D:33.80 N:11.70 | デニム用 for denim | 14 16 18 90 100 110 | |
| HA × 1GT | |  |  | A:2.02 D:33.80 N:11.70 | ジョーゼット用 for georgette | 7 55 | |
| HA × 1LL | 15 × 2NTW 130LL 130/705HLL |  |  | A:2.02 D:33.80 N:11.70 | レザー用 for leather | 11 12 14 16 21 75 80 90 100 130 | |
| HA × 1SP | |  |  | A:2.02 D:33.80 N:11.70 | ニット用 for knitted fabrics | 9 10 11 12 14 65 70 75 80 90 | |
| HA × 1QU | |  |  | A:2.02 D:33.80 N:11.70 | キルト用 for quilting | 11 14 75 90 | |
| HA × 1EB | |  |  | A:2.02 D:33.90 N:11.70 | 刺繍用 for embroidery | 11 14 75 90 | |
| HA × 1BR | |  |  | A:2.02 D:33.80 N:12.50~11.70 | 家庭用ミシン針 for home sewing machine | 9 11 14 16 65 75 90 100 | |
| EL × 705 | |  |  | A:2.02 D:33.90 N:11.50 | 家庭用ロック針 for home overlock | カバーステッチ用 for cover stitches | 11 12 14 75 80 90 |
| BL × 1 | |  |  | A:1.62 D:33.80 N:13.50 | ベビーロック職業用 for babylock | 9 10 11 12 14 16 65 70 75 80 90 100 | |
| HL × 5 | |  |  | A:2.00 D:33.90 N:12.50 | 家庭用ロック針 for home overlock | 職業用 for professional | 9 10 11 12 14 16 18 20 65 70 75 80 90 100 110 125 |
| DC × 1F | |  |  | A:2.02 D:28.60 N:10.00 | ベビーロック用 (DC × 1の平取針) babylock (DC × 1 with flat shank) | 9 11 12 14 16 18 65 75 80 90 100 110 | |
| DC - C87 | |  |  | A:2.02 D:28.60 N:10.00 | ベビーロック用 (DC × 1KNの平取針) babylock (DC × 1KN with flat shank) | 9 10 11 12 14 65 70 75 80 90 | |
| | | | | | | | |
| | | | | | | | |
| | | | | | | | |
| | | | | | | | |

上記以外にも様々な種類の針があります。詳しくは、お問い合わせください。/ Please Note: we have many other types of needles that are not indicated above. Please contact us for details.

ミシン針相談のご案内

SEWING MACHINE NEEDLES INQUIRIES

縫紉機針諮詢服務的介紹

縫製トラブルが解消しないときに、適正針選定のお手伝いをします。

For ongoing sewing problems, we can help by recommending the appropriate needle.

縫製問題無法解決時,敝公司為您提供選定合適縫紉機針的幫助。

お申し込みの流れ / Application Process / 申請流程

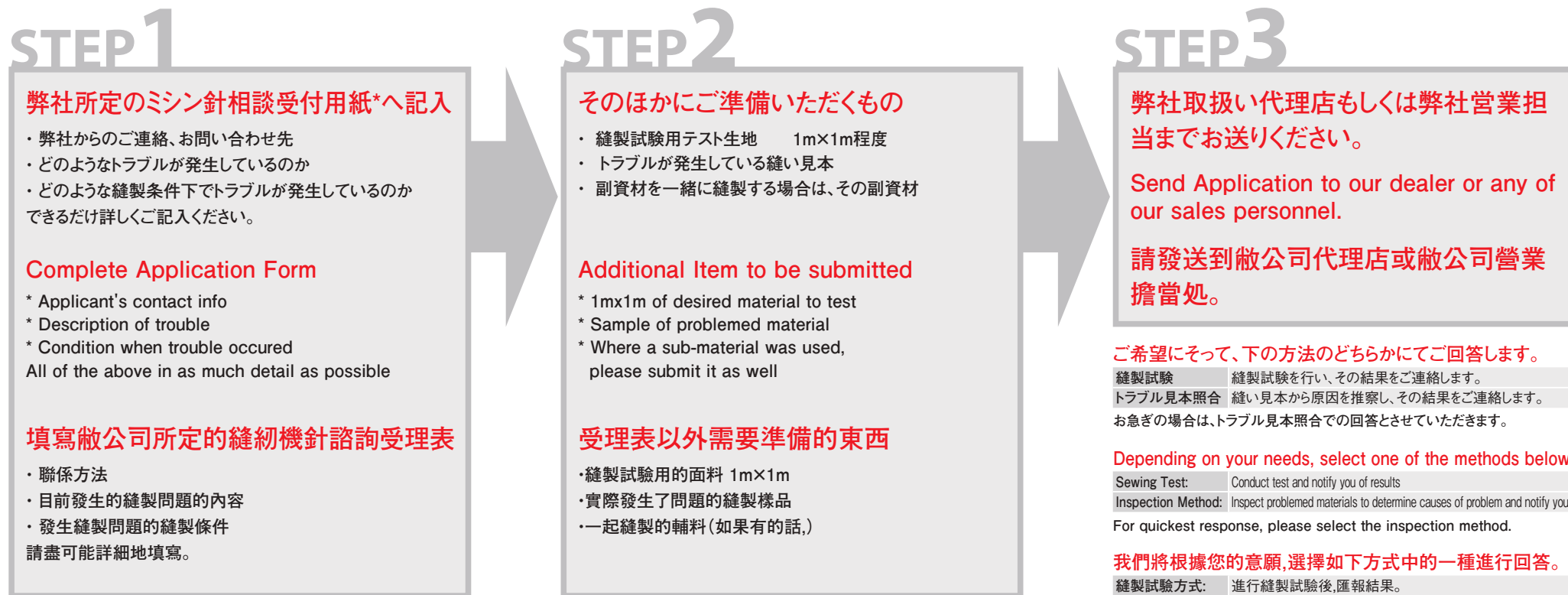

* ミシン針相談受付用紙は、弊社のホームページより日本語版のみダウンロードできます。

URL: <http://www.organ-needles.com/pdf/trouble2.pdf>

オルガン針株式会社トップページの左側メニューより、縫製トラブル対策情報>ミシン針相談受付用紙
尚、ミシン針相談受付用紙にご記入の際は、記載されている事項をよくご確認のうえ、詳しくご記入ください。
英語版、中国語版の受付用紙については、営業担当にお問い合わせください。

To obtain an English copy of the application, please contact any of our sales personnel.

中文版的縫紉機針諮詢受理表,請向敝公司營業擔當詢問。

ミシン針相談についてご不明な点は、営業担当にお問い合わせください。

For any further information required, please contact any of our sales personnel.

如果您對縫紉機針諮詢服務有任何不明之處,請向敝公司營業擔當詢問。

縫製トラブルと対策針 薄物生地縫製

(アパレル・ファンデーション・スポーツウェア)

SEWING TROUBLE and COUNTERMEASURE

-Needle for thin fabrics sewing (Apparel・Underwear・Sportswear)-

縫紉問題及対策針

～軽薄面料的(服装縫製・內衣縫製・運動服縫製)～

| トラブル | TROUBLE | 縫紉問題 | 素材 | MATERIAL | 面料 | 原因 | CAUSE | 原因 | 対策針 SUGGESTED NEEDLE | 対策針 |
|----------|-------------------------------------|--------|-------------|---------------------------|-----------|-------------------|--|---------------|-----------------------------------|-----|
| 地糸切れ | Fabric Yarn Breakage | 面料断线 | ニット | Knit | 針織面料 | 針の先端と太さで切断する | Unsuitable Point Size and Thickness | 針太尖且太粗而切断 | Ball point series KN/SF series | |
| | | | 布帛 | Woven | 機織面料 | 針の太さで切断する | Unsuitable Thickness | 針太粗而切断 | NS series | |
| | | | ネット | Net | 網状面料 | 針の先端で切断する | Unsuitable Point Size | 針太尖而切断 | Ball point series | |
| | | | | | | 針が深く刺さる | Needle Penetrates up to Shank Taper | 針刺入太深 | KK series | |
| | | | | | | 熱で切断する | Heat Buildup | 針發熱而切断 | HP coating | |
| 目飛び | Skipped Stitches | 跳线 | | | | 針振れ・ループが不安定 | Needle Deflection・Poor Loop Formation | 針晃動,線抛不穩定 | NY2 series SK series | |
| バックリング | Seam Puckering | 縫縮起皺 | | | | 生地をばたつかせる | High Friction/Resistance between Needle and Material | 面料上下擺動 | NS series LP coating | |
| ダウンの噴出し | Leaking Down | 羽絨面料粘毛 | 布帛 | Woven | 機織面料 | 針穴跡が大きい | Poor Seam Appearance | 針孔留下的痕迹過大 | NS series | |
| | | | | | | 針がダウンを引き上げる | Down Clinging to Needle | 針會把羽絨帶上來 | LP coating | |
| | | | ニット | Knit | 針織面料 | 地糸切れした穴からダウンが噴き出す | Inside Down Leaks out from Fabric Yarn Breakage Hole | 羽絨从面料断线的針洞中露出 | KN/SF series | |
| 糸引け | Needle Line | 急針 | 斜紋織・朱子織 | Twill Weave/Sateen Weave | 斜紋面料・緞紋面料 | 織糸を寄せる | Loose Woven Yarn | 縫綫將織綫擠開 | NS series | |
| 糸返り | Pulling Linings out of Needle Holes | 露白 | プリント生地 | Printed Material | 印花面料 | 織糸が裏返る | Loose Woven Yarn with Strands | 織綫翻轉 | Ball point series KN/SF series | |
| 突き出し | Protrusion | 頂出 | ゴム | Gum | 松緊帶 | 針先端でゴムを突き出す | Gum Protrusion | 針尖造成的橡皮筋突刺 | Ball point series | |
| | | | 布帛 | Woven | 機織面料 | 柄がずれる | Visible Yarn Movement | 花紋紊亂 | Ball point series NS series | |
| | | | | | | 針で織糸を解撚する | Twist Displacement of Woven Yarn | 針造成的織綫解撚 | Ball point series | |
| スパンコール割れ | Sequins Breakage | 珠片破碎 | 穴の小さなスパンコール | Sequins with a Small Hole | 小孔珠片 | 針のテーパ部が生地に入る | Needle Penetrates up to Shank Taper | 針後端的錐形部分會穿過麵料 | KK series | |



ORGAN NEEDLE CO., LTD.

販売ネットワーク/SALES NETWORK/營業網點

オルガン針株式会社

〒386-1436 長野県上田市前山1番地
Tel:0268-35-3615 Fax:0268-35-3623
www.organ-needles.com
E-mail: sales-dpt@organ-ndl.co.jp

ORGAN NEEDLE CO., LTD.

1Maeyama, Ueda-shi, Nagano-ken 386-1436, Japan
Tel:+81-268-35-3615 Fax:+81-268-35-3623
www.organ-needles.com
E-mail: sales-dpt@organ-ndl.co.jp

■東京営業所

〒110-0015 東京都台東区東上野3-16-1オルガンビル
Tel:03-3833-1081 Fax:03-3835-7848
E-mail: tokyo@organ-ndl.co.jp

Tokyo Office

Organ Bldg., 3-16-1 Higashiueno, Taito-ku,
Tokyo 110-0015, Japan
Tel:+81-3-3833-1081 Fax:+81-3-3835-7848
E-mail: tokyo@organ-ndl.co.jp

■大阪営業所

〒540-0012 大阪府大阪市中央区谷町1-4-2オルガンビル
Tel:06-6941-9735 Fax:06-6943-6782
E-mail: osaka@organ-ndl.co.jp

Osaka Office

Organ Bldg., 1-4-2 Tanimachi, Chuo-ku, Osaka-shi,
Osaka 540-0012, Japan
Tel:+81-6-6941-9735 Fax:+81-6-6943-6782
E-mail: osaka@organ-ndl.co.jp

風琴針業有限公司

香港香港仔黃竹坑道26號建德工業大廈15字樓
Tel:+852-2552-8262 Fax:+852-2873-6037

ORGAN NEEDLE CO., LTD.

Kin Teck Industrial Bldg., 15th Floor,
26Wong Chuk Hang Road, Aberdeen,
P. R. O. C. Special Administration Region, Hong Kong
Tel:+852-2552-8262 Fax:+852-2873-6037

風琴針業(上海)有限公司

郵編200040
中國上海市北京西路1277號國旅大廈1007室
Tel:+86-21-6279-3330 Fax:+86-21-6279-1109

ORGAN NEEDLE (SHANGHAI) CO., LTD.

Room No.1007, Guo Lu Bldg., No.1277 Beijing West Road,
Shanghai, China 200040
Tel:+86-21-6279-3330 Fax:+86-21-6279-1109

重慶風琴針業有限公司

郵編401122
中國重慶市北部新區金渝大道102號附1號
Tel:+86-23-8607-6080/6087 Fax:+86-23-6746-3408

CHONGQING ORGAN NEEDLE CO., LTD.

No.102-1 of Jinyu Road, New North Zone, Chongqing,
China 401122
Tel:+86-23-8607-6080/6087 Fax:+86-23-6746-3408

台灣風琴針貿易股份有限公司

台灣台北市承德路三段30號3F
Tel:+886-2-2585-5190/5193 Fax:+886-2-2585-5182

TAIWAN ORGAN NEEDLE TRADING CO., LTD

3F., No.30, Sec.3, Cheng-The Road, Taipei, Taiwan
Tel:+886-2-2585-5190/5193 Fax:+886-2-2585-5182

ORGAN NEEDLE (SINGAPORE) CO. PTE LTD.

No.190, Middle Road, #13-05 Fortune Centre,
Singapore 188979
Tel:+65-6339-3581/3588 Fax:+65-6339-5550

風琴針業(新加坡)私人有限公司

No.190, Middle Road, #13-05 Fortune Centre,
Singapore 188979
Tel:+65-6339-3581/3588 Fax:+65-6339-5550

ORGAN NEEDLE EUROPE GmbH

Kesselsgracht 7, D-52146 Würselen, Germany
Tel:+49 2405 4992 120 Fax:+49 2405 4992 125

ORGAN NEEDLE EUROPE GmbH

Kesselsgracht 7, D - 52146 Wuerselen, Germany
Tel:+49 2405 4992 120 Fax:+49 2405 4992 125

CÔNG TY TNHH THƯƠNG MẠI KIM MAY ORGAN VIỆT NAM

Tầng 7, Số 400 Đường Nguyễn Thị Thập,
Phường Tân Quy, Quận 7, Thành phố Hồ Chí Minh
Tel: (84)-08-37718025 - (84)-08-37718026
Fax:(84)-08-37718027

ORGAN NEEDLE TRADING VIETNAM CO., LTD.

7F., 400 Nguyen Thi Thap str., Tan Quy ward, District 7,
Ho Chi Minh City, Vietnam
Tel:+84-8-3771-8025/8026 Fax:+84-8-3771-8027

URL: <http://www.organ-needles.com/>

弊社ホームページより当カタログをダウンロードできます。

This brochure can be downloaded from our site.

從弊公司主頁能夠下載產品目錄